

Status: 03/2026

cab
we identify more

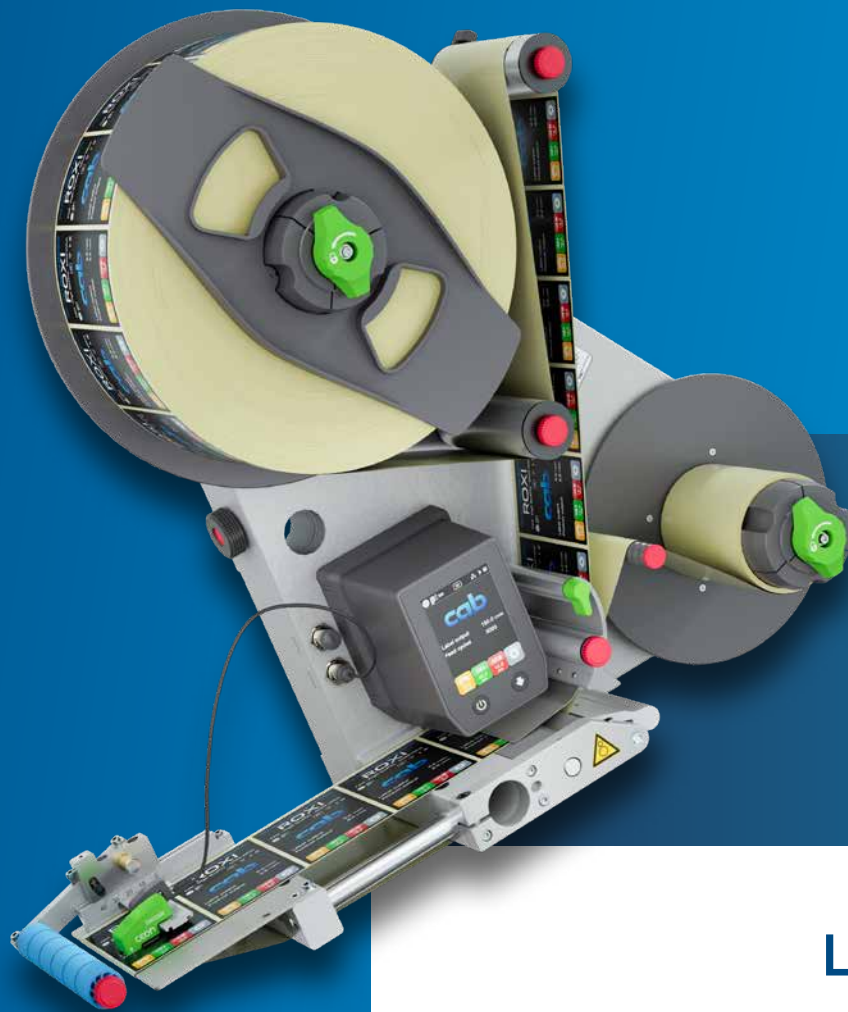

ROXI and IXOR⁺

Labeling heads for
precise insert labeling

Made in Germany

Overview of labeling heads

ROXI IXOR+

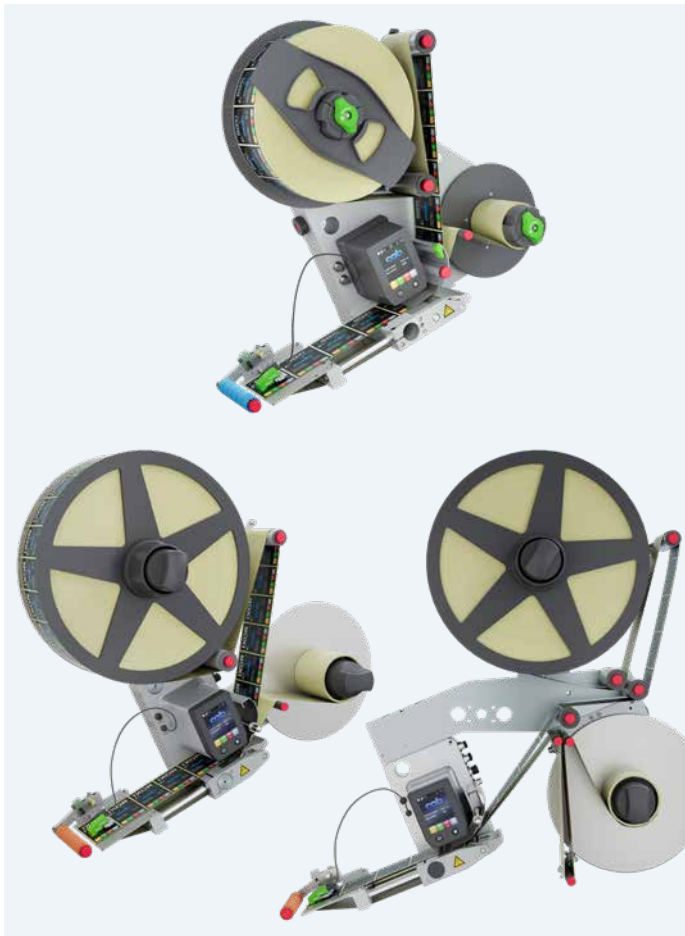

ROXI labeling heads

for label webs running as fast as 30 m/min

Roll diameter	max. 310 mm
Width of material	max. 180 mm

IXOR+ labeling heads

for label webs running as fast as

- 50 m/min with a mechanical unwinder and a mechanical rewinder
- 75 m/min with a mechanical unwinder, motoric rewinder
- 120 m/min with a motoric unwinder and a motoric rewinder, 200 m/min upon request

Modular construction; rewinders / unwinders can be assembled independent from a base unit

Roll diameters	max. 410 mm / 510 mm upon request
Widths of material	max. 186 mm / 248 mm, 310 mm upon request

Peripherals



PX QS print modules and loop control installed at a minimum depth of 100 mm behind the material-locating edge

for ROXI, IXOR and IXOR+ labeling heads
 Technical data correspond with PX Q print modules
 Available from end of quarter 2/2026
 See separate data sheet of PX QS print modules

ROXI with HERMES HQ applicators for labeling items at rest

for ROXI labeling heads
 Technical data correspond with HQ applicators
 See separate data sheet

Labeling heads by comparison

ROXI IXOR+

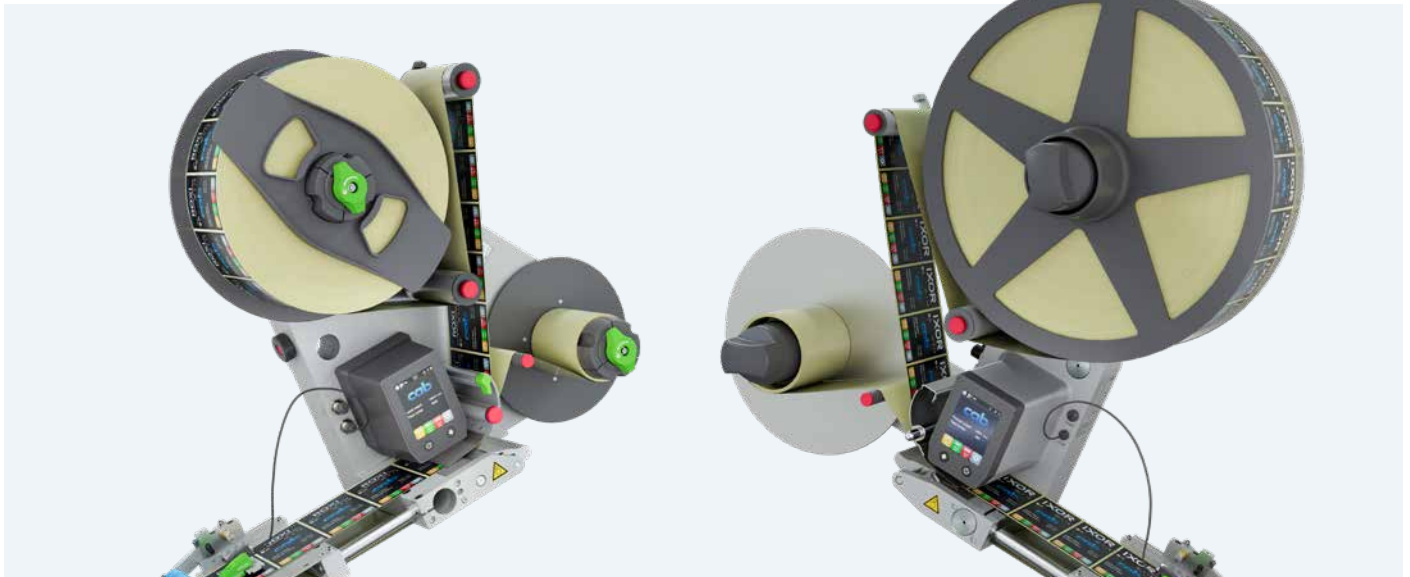

ROXI

One unit for any application
 as fast as 30 m/min
 Roll diameter max. 310 mm
 vertical and horizontal, as requested
 IP 40: Protected against solid foreign objects Ø 1.0 mm and larger
 Not protected against water
 Cold device socket
 RJ45
 Two A type USB hosts

Differences

Design	Modular; rewinders / unwinders can be assembled independent from a base unit
Label web speed	as fast as 120 m/min (200 m/min upon request)
Unwinders	Roll diameter max. 410 mm / 510 mm upon request
Installation	Vertical, taking an extended sleeve retainer into consideration for margin stop
Protection class	IP 66: Dustproof Protected against powerful water jets
Power supply	M12 circular connector
Ethernet	M12 circular connector
APPLY	M12 circular connector for one USB host (via adapter cable) Peripheral interface for connecting a printer and controlling a label transfer unit Configurable I/O interface with two inputs and one output

IXOR+

Common features

Installation dimensions
Firmware
User interface
Demand modules
Wipe-down rollers
Sensors
Interfaces
Accessories
Assembly assistance

ROXI labeling head for label webs running as fast as 30 m/min

- Precise insert labeling
- Solid construction, perfect in every way
- Advanced electronics and software
- Small price – great performance
- A future-proof investment

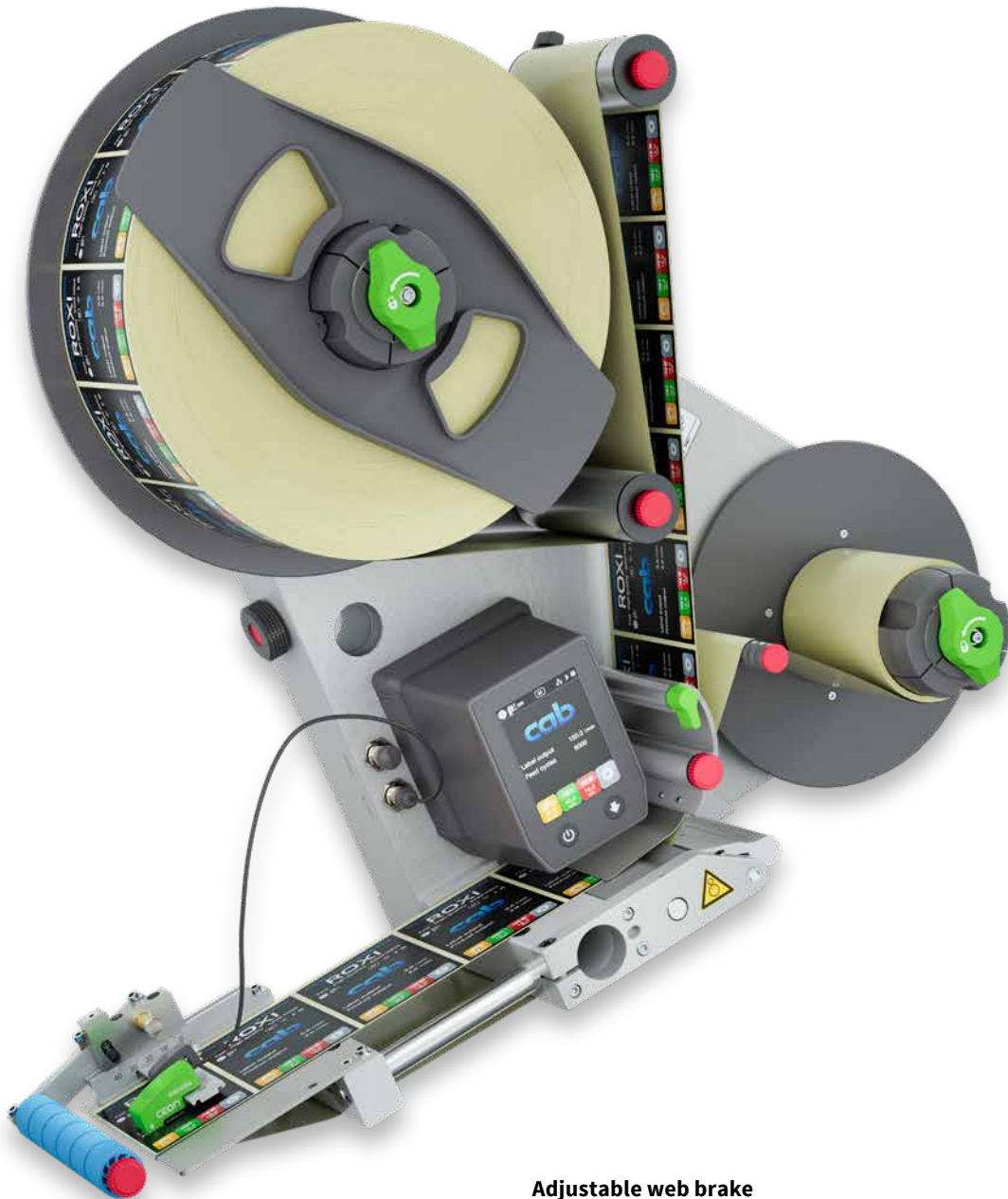

Compact and slim design

Easy to install into production lines or labeling systems

Any assembly

Vertical, horizontal, inclined, providing labels to the left or right

High quality and reliability

Tried and tested functional modules Made in Germany

Durable and easy to maintain

Designed for continuous industrial use

Free firmware updates via Ethernet, USB interface or FTP software

Adjustable web brake

It helps with sensitive stamped parts and materials that are difficult to dispense. In cases of material changeover, simply open and close it using the lever.

Dynamic speed control

A label web is fed automatically by a masterencoder (rotary → linear upon request) synchronous to the speed of an item on a conveyor.

Safety guaranteed

Certified by independently authorized testing labs

Short setup times

Quick and simple material changeover

Useful accessories

Columns, stands, connecting cables, and many others help with installation ready for use.

Labeling head

Mechanical unwinders and rewinders

for label webs running as fast as 50 m/min
 Roll diameters 310 mm and 410 mm
 Unwinders and demand units can be assembled also independent from a base unit

Vertical installation:

The sleeve core is extended by 62 mm relative to the rewriter to accommodate and clamp the counterholder.

The labeling head can also be assembled horizontally.

Horizontal installation:

There is no counterholder. The sleeve cores of the unwinder and rewriter are the same length.

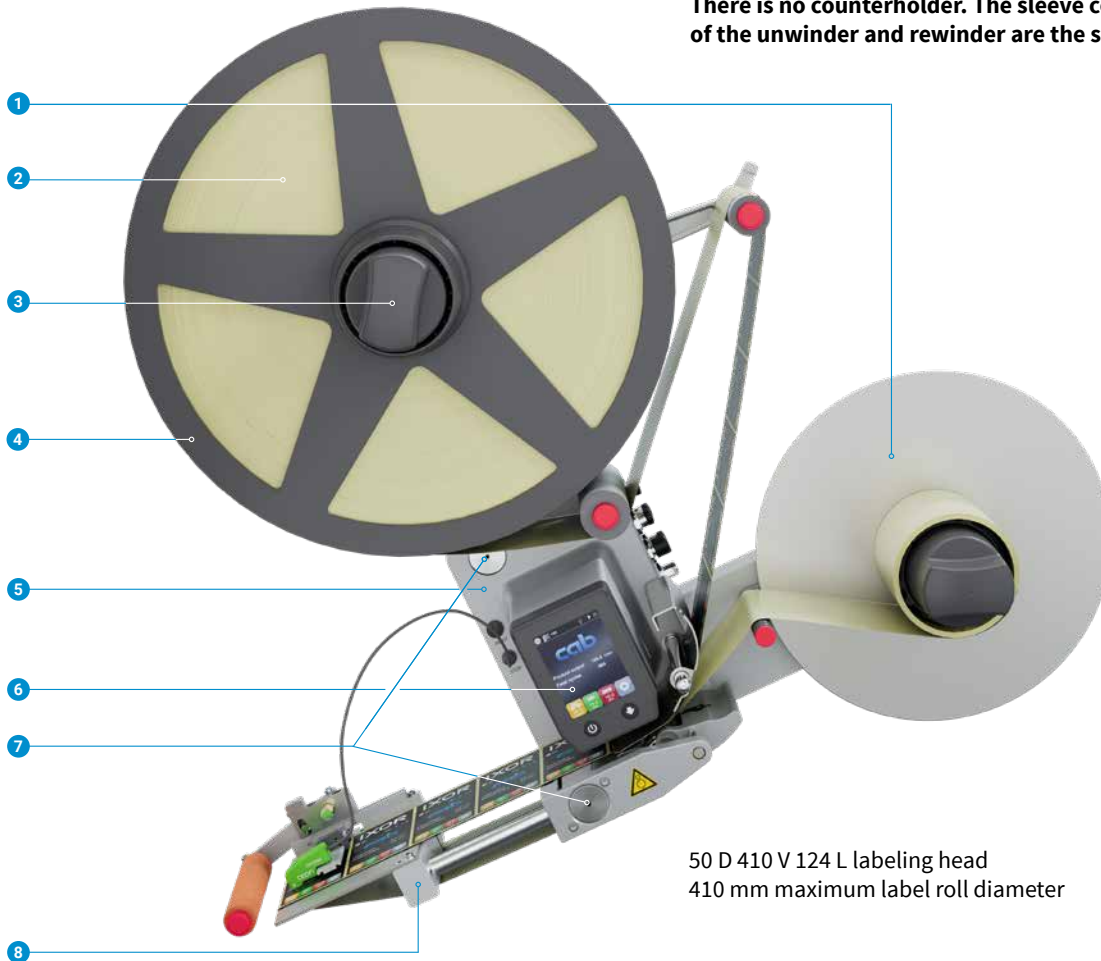

50 D 410 V 124 L labeling head
 410 mm maximum label roll diameter

1 Rewinder

The liner is wound when labels have been dispensed. A pendulum arm and an integral clutch keep the liner under constant tension in subsequence to the drive roller.

2 Unwinder

picking up label rolls with a maximum diameter of 410 mm. A pendulum arm and an integral brake keep a label web under constant tension.

3 Sleeve retainer

Turning the handle tensions and releases the label roll sleeve.

4 Unit retainers

for securing and guiding a label roll when installed in vertical orientation. For this purpose, the sleeve retainer is designed 62 mm longer than in horizontal installation.

5 Base unit

It is the center of a labeling head and contains the drive roller for feeding a label web, a brushless servo motor and the system control including the operation panel.

6 Operation panel

Color 3.5" LCD touchscreen
 Rotation by 180° enables overhead installation.

7 Pick-up spots

for assembly onto columns with a diameter of 30 mm. Label positions on a product can thus be set transversely to its direction of running.

8 Demand unit

It can be configured for specific applications using a comprehensive modular system.

Labeling head

Motoric unwinders and rewinders

for label webs running as fast as

- 75 m/min with a mechanical unwinder, motoric rewriter
- 120 m/min with a motoric unwinder and a motoric rewriter, 200 m/min upon request

Roll diameter 410 mm (510 mm upon request)

Modular construction:

A base unit, unwinder and rewriter are installed on a mounting strip. The modules can be positioned also on a carrier plate according to customer specifications.

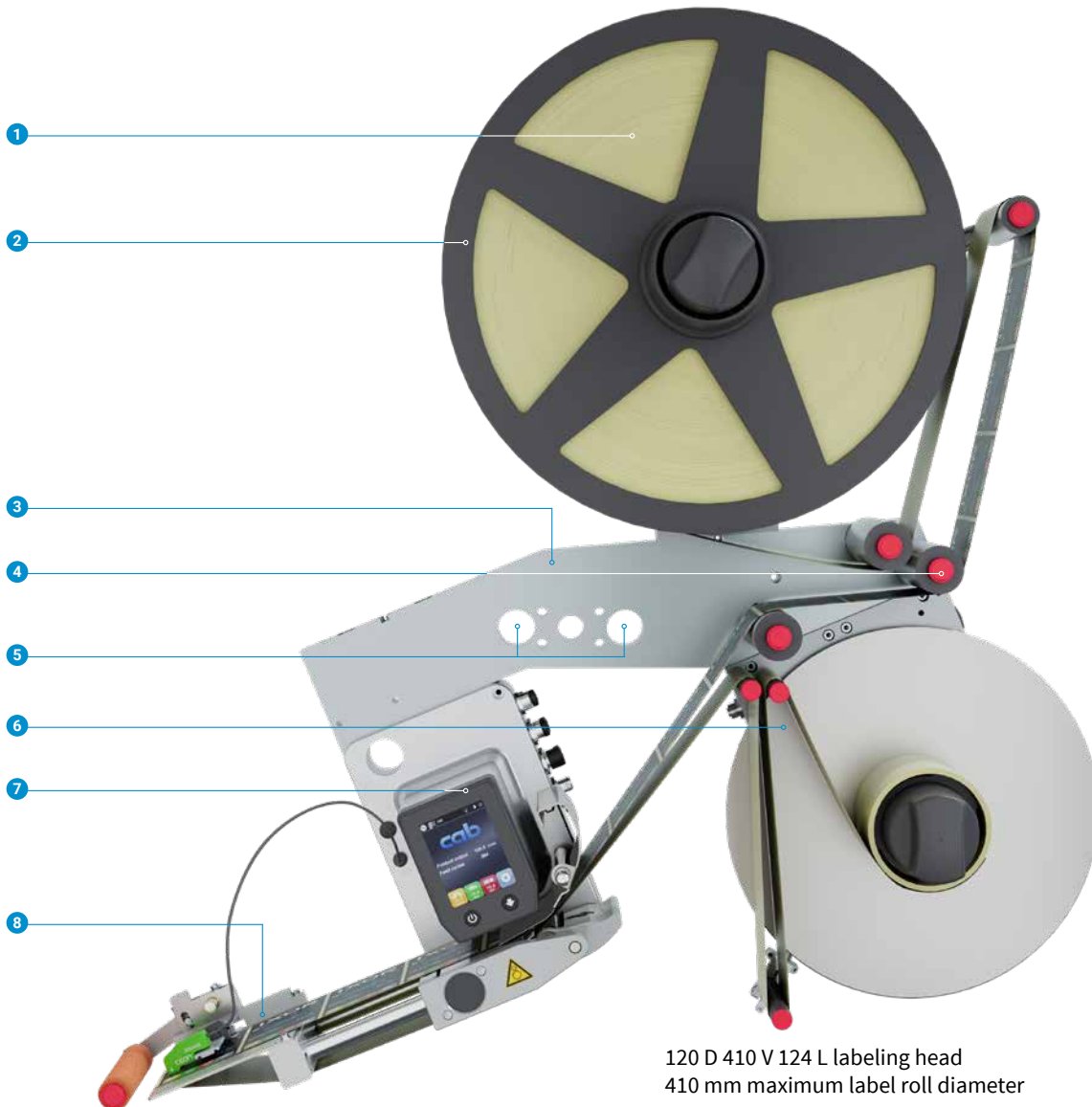

120 D 410 V 124 L labeling head
410 mm maximum label roll diameter

- 1 Mechanical or motoric unwinder**
picking up label rolls with a maximum diameter of 410 mm (510 mm upon request). With a motoric unwinder in use, the roll is driven by an integral brushless torque motor. The label web unwinds according to the pendulum arm. A label web speed is automatically activated as soon as the motoric unwinder has been connected.
- 2 Counterholder**
for securing and guiding a label roll when installed in vertical orientation. For this purpose, the sleeve retainer is designed 62 mm longer than in horizontal installation.
- 3 Mounting strip**
for assembling a base unit, motoric unwinder, rewriter
- 4 Deflection rollers**
They are guiding a label web from a motoric unwinder to the base unit.
- 5 Pick-up spots**
for assembly onto a column stand. Label positions on a product can thus be set transversely to its direction of running.
- 6 Motoric rewriter**
The liner is wound when labels have been dispensed. A pendulum arm and an integral brushless torque motor keep a label web under constant tension in subsequence to the drive roller. Any kind of installation is possible. A label web speed is automatically activated as soon as the motoric rewriter has been connected.
- 7 Base unit**
It is assembled to the mounting strip. A PowerBus module is installed for connecting motoric winders.
- 8 Demand unit**
It can be configured specific to applications using a comprehensive modular system.

Operation panel

ROXI IXOR⁺

Intuitive and easy to operate
Rotatable by 180°, depending
on the installation of a unit.

Unit configuration with the help of self-
explanatory symbols on the user interface



Firmware

ROXI IXOR+

Embedded Linux operating system



- Support 'out-of-the-box' of Open Source bundles and interfaces, such as FTP, SSL, Avahi/Zeroconf

- Regular updates for hotfixes and official CVE security patches



- Comprehensive release notes with each update

Compatibility of labeling heads



- Same codebase on ROXI and IXOR+

- Identical firmware file in preparation

- Further developments are immediately available on every unit.

Maintenance and diagnostics



- Web Interface

- Event log for activity tracking

- Diagnostics files in standardized XML text format

Interfaces and user-specific features

	USB stick	Web interface	FTP software
Access to entire documentation of a unit	✓	✓	✓
Backup and restore	✓	✓	✓
Configuration reading and import	✓	✓	✓
Firmware update	✓		✓



VNC LAN / WLAN

Remote control by a PC, smartphone, tablet

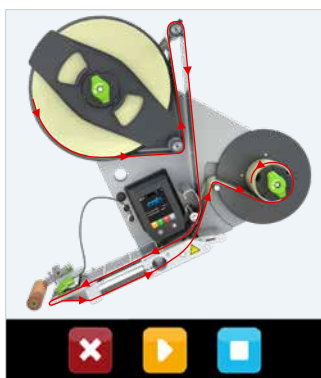

Feed path schemes

On display

Upgrades

- Protocols such as MQTT as well as features like the masterencoder can be unlocked by key (online purchase).

Remote support

- Diagnostics service by use of an existing customer network

- Special software oscilloscope, maximum resolution 1 ms, for unlimited use during production

Integral Ethernet protocols for higher-level machine control systems

• MQTT, ModBus TCP

• OPC UA



- Profinet available from end of quarter 2/2026

- Access via PLC and an industrial PC to parameters, I/O signals, error messages

- Unlocked by key

Redundancy

- Two labeling heads can be operated redundantly and continually in an Ethernet network.

- While one dispenser actively applies labels onto items, another unit is on standby. In cases of a malfunction on an active unit (e.g. a label web ending), the second takes over immediately.

- All items located between the units are labeled.

- The product sensor and the rotary encoder each are provided once for both labeling heads.

Signals are transmitted to both labeling heads via a distributor.

- An adapter is required for Ethernet connection.

- Unlocked by key

Interfaces



- 1 **Power plug**
- 2 **Cold device socket**
- 3 **Two USB hosts**
for a warning light, an external operation panel, USB / WLAN stick
- 4 **Ethernet**
TCP/IP data transmission
- 5 **START**
By signal, for example a product sensor
- 6 **I/O**
Compliant to IEC/EN 61131-2, type 1+3
All inputs and outputs protect from reverse polarity.
Outputs are also short-circuit proof
- 7 **SYNC**
A label web is synchronized by a masterencoder (rotary → linear upon request) to the speed of an item on a conveyor



Digital inputs

- Labeling head ON
- Pre-dispense
- Start labeling
- Start labeling locked
- Error reset
- User-defined

Digital PNP outputs

- Labeling head ready
- Pre-dispense
- Stop label feed
- Label feed running
- Label missing on liner
- End of label web
- Prior warning to label web ending
- Error
- User-defined

Analog inputs

- Speed
- Start delay
- Stop delay

Status indications on the operation panel

all inputs and outputs
 Helpful with initial setup, especially when integrating a labeling head in external control systems
 Inputs and outputs can be simulated or forced for testing purposes.

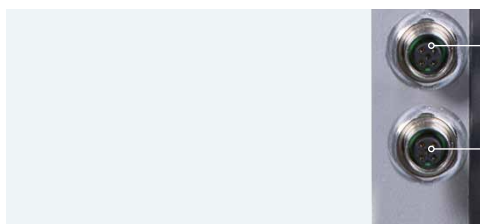

- 8 **PRINT & APPLY**
Peripheral interface for plugging a printer and controlling a transfer unit with 24 VDC
- 9 **STOP**
Plug of a label sensor for detecting the leading edge of a label optically or inductively

○ Plug and PIN assignment compatible with IXOR+

Interfaces



Motoric unwinder, rewriter



- 1 END/DIM**
Mechanical unwinder sensor input
Prior warning to a label web ending, label web ending, broken liner
 - 2 Ethernet**
TCP/IP data transfer
 - 3 I/O**
Compliant to IEC/EN 61131-2, type 1+3
All inputs and outputs protect from reverse polarity.
Outputs are also short-circuit proof

Digital inputs Labeling head ON Pre-dispense Start labeling Start labeling locked Error reset User-defined	Digital PNP outputs Labeling head ready Pre-dispense Stop label feed Label feed running Label missing on liner End of label web Prior warning to label web ending Error User-defined
---	--
 - 4 START**
By signal, for example a product sensor
 - 5 APPLY**
USB host (via adapter cable)
Peripheral interface for plugging a printer and controlling a transfer unit according to **9**
I/O, configurable with two inputs and one output
Compliant to IEC/EN 61131-2, type 1+3
All inputs and outputs protect from reverse polarity.
Outputs are also short-circuit proof.
An external operation panel or a warning light may be as well plugged.
 - 6 SYNC**
A label web is synchronized by a masterencoder (rotary → linear upon request) to the speed of an item on a conveyor
 - 7 POWER IN**
Input voltage 100 V to 240 V, 50 Hz to 60 Hz
 - 8 WLAN**
integral to the operation panel
 - 9 PRINT & APPLY**
Peripheral interface for plugging a printer and controlling a transfer unit with 24 VDC
 - 10 STOP**
Plug of a label sensor for detecting the leading edge of a label optically or inductively
 - 11 PowerBus IN**
Input voltage 100 V to 240 V, 50 Hz to 60 Hz
 - 12 PowerBus OUT**
Output voltage 100 V to 240 V, 50 Hz to 60 Hz
- Status indications on the operation panel**
all inputs and outputs
Helpful with initial setup, especially when integrating a labeling head in external control systems
Inputs and outputs can be simulated or forced for testing purposes.
- Plug and PIN assignment compatible with ROXI

Technical data

ROXI

Width of a roll on ROXI		mm max.	60	120	180
Label web speed	m/min max.		30	30	30 ²⁾
Cycle rate	labels/min		It is determined by the length of a label and the speed of an item running on a conveyor and can be simulated on the operation panel.		
Installation			vertical / horizontal		
Direction to which labels are provided			L = to the left, R = to the right		
Material¹⁾					
Label	on a roll		paper, synthetics PET, PE, PP, PVC / booklets upon request		
	Width mm		10 - 56	10 - 116	10 - 176
	Length at feeding mm		10 - 6,000		
	Gap mm at least		2		
	Thickness mm		0.055 - 1.0		
Liner	Width mm		15 - 60	15 - 120	15 - 180
Roll	Weight kg max.		12		
Unwinder	Outside diameter mm		310		
	Core diameter mm		76		
	Winding		outside or inside		
Rewinder	Outside diameter mm		210		
	Core diameter mm		76		
Label sensor					
Distance to locating edge	Features		detection of label margins and materials ending		
	CEON mm		9 - 30	9 - 60	9 - 90
	GAB 500-1 mm		7.5 - 17.5		
	GAB 500-2 mm		8 - 40		
Operating data					
Voltage			100 - 240 V~, 50 - 60 Hz		
Current consumption			100 VAC up to 2 A / 240 V up to 1 A		
Temperature / humidity	Operation		5° - 40 °C / 10 % - 85 %, not condensing		
	Stock		0° - 60 °C / 20 % - 85 %, not condensing		
	Transport		-25° - 60 °C / 20 % - 85 %, not condensing		
Approvals			CE, FCC Class A, ICES-3		
	in preparation		cULus, CB		
Protection class			IP 40		
Operation panel					
	LED		ON / OFF, FEED		
	LCD graphics display Width x Height mm		54 x 70		
Control					
			Prior warning to a label web ending, broken liner torque, temperature, voltage		

¹⁾ Limitations can occur when processing small labels, thin materials or materials using a strong adhesive. Such applications require testing.

²⁾ Calculated using a roll as wide as 180 mm and labels 98 mm long. Other dimensions require testing.

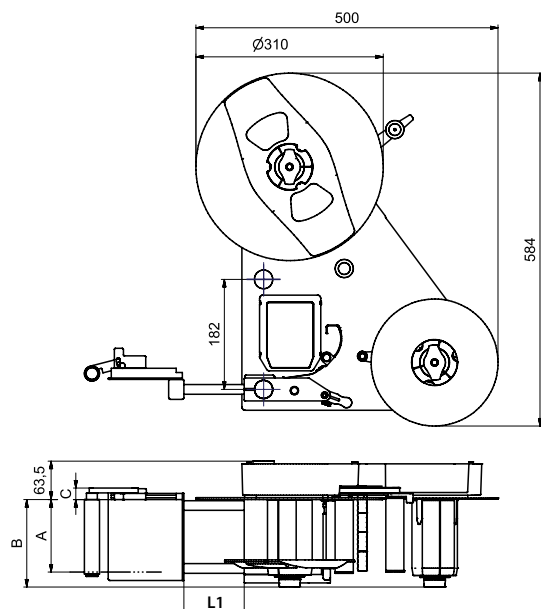

Labeling head	Dimensions A mm	Dimensions B mm	Weights kg
ROXI 60	60	140	11.5
ROXI 120	120	145	12
ROXI 180	180	205	13

Demand module	Dimensions C mm
SP	19
SPE	24
SPFA	19

Mounting rod	Dimensions L1 mm
MS 25	25
MS 100	100
MS 200	200
MS 300	300
MS 400	400

Scopes of delivery, designs and technical data correspond to the date of this publication. They are subject to change. Catalogue data do not represent any warranty or guarantee.

Technical data

IXOR+

Width of a roll on IXOR+		mm max.	62	124	186
Label web speed when operating					
mechanical unwinder, rewinder	m/min max.		50		
mech. unwinder, motoric rewinder	m/min max.		75		
motoric unwinder, rewinder	m/min max.		120 (200 upon request)		
Cycle rate		labels/min	It is determined by the length of a label and the speed of an item running on a conveyor and can be simulated on the operation panel.		
Installation			vertical / horizontal		
Direction to which labels are provided			L = to the left, R = to the right		
Material¹⁾					
Label		on a roll	paper, synthetics PET, PE, PP, PVC / booklets upon request		
	Width	mm	10 - 58	10 - 120	10 - 182
	Length at feeding	mm	10 - 6,000		
	Gap	mm at least	2		
	Thickness	mm	0.055 - 1.0		
Liner	Width	mm	15 - 62	15 - 124	15 - 186
Roll	Weight	kg max.	15		
Unwinder	Outside diameter	mm	mechanical 310, 410 / motoric 410 (510 upon request)		
	Core diameter	mm	76		
	Winding		outside or inside		
Rewinder	Outside diameter	mm	mechanical 210, 290 / motoric 310 (410 upon request)		
	Core diameter	mm	92		
Label sensor					
		Features	detection of label margins and materials ending		
Distance to locating edge	CEON	mm	9 - 30	9 - 60	9 - 90
	GAB 500-1	mm	7.5 - 17.5		
	GAB 500-2	mm	8 - 40		
Operating data					
Voltage			100 - 240 V~, 50 - 60 Hz		
Current consumption			100 VAC up to 5 A / 240 VAC 2,5 A		
Temperature / humidity	Operation		5° - 40 °C / 10 % - 85 %, not condensing		
	Stock		0° - 60 °C / 20 % - 85 %, not condensing		
	Transport		-25° - 60 °C / 20 % - 85 %, not condensing		
Approvals			CE, FCC Class A, ICES-3, cULus, CB		
Protection class			IP 66		
Operation panel					
		LED	ON / OFF, FEED		
LCD graphics display		Width x Height mm	54 x 70		
Control					
Prior warning to a label web ending, label web ending, broken liner torque, temperature, voltage					

¹⁾ Limitations can occur when processing small labels, thin materials or materials using a strong adhesive. Such applications require testing.

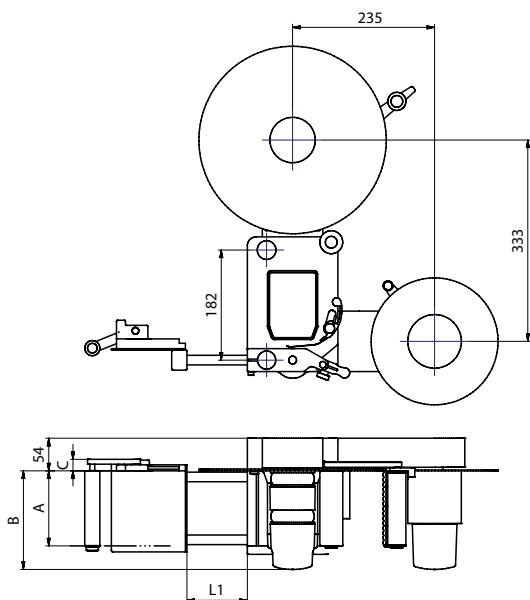

	Dimensions A mm	Dimensions B mm Installation	
		vertical	horizontal
Width of a roll	62	163	163
	124	225	163
	186	287	225

Demand module	Dimensions C mm	Mounting rod	Dimensions L1 mm
SP	19	MS 25	25
SPE	24	MS 100	100
SPFA	19	MS 200	200
		MS 300	300
		MS 400	400

Scopes of delivery, designs and technical data correspond to the date of this publication. They are subject to change. Catalogue data do not represent any warranty or guarantee.

Demand units

ROXI IXOR⁺

They have a modular design.

Settings for wipe-down rollers, brushes and sensors can be reproduced using scales.

All adjustments can be made with a Torx screwdriver even during labeling.

Wear parts such as wipe-down rollers and brushes can be replaced without additional tools for maintenance or cleaning, so can deflection rollers.

Adaptation in five steps:

1. Demand module

A label is inserted from the side.
A module can be configured as required.

2. Carriage

It is used for adjusting the distance of a wipe-down roller respectively brush to the peel-off plate.

3. Wipe-down roller or brush

Labels when attached insert are precisely applied onto items using a roller or a brush. These can be precisely tailored to an item for optimum labeling.

4. Mounting rods

They are assembled both to the profiles of a demand module and a labeling head.

5. Label sensors

Label positions are detected exactly,
high repetition accuracy included

Simple assembly:

- A** inductive CEON on dispenser tongue
- B** Forked light barrier GAB 500-1 on demand module
- C** Forked light barrier GAB 500-2 on retainer

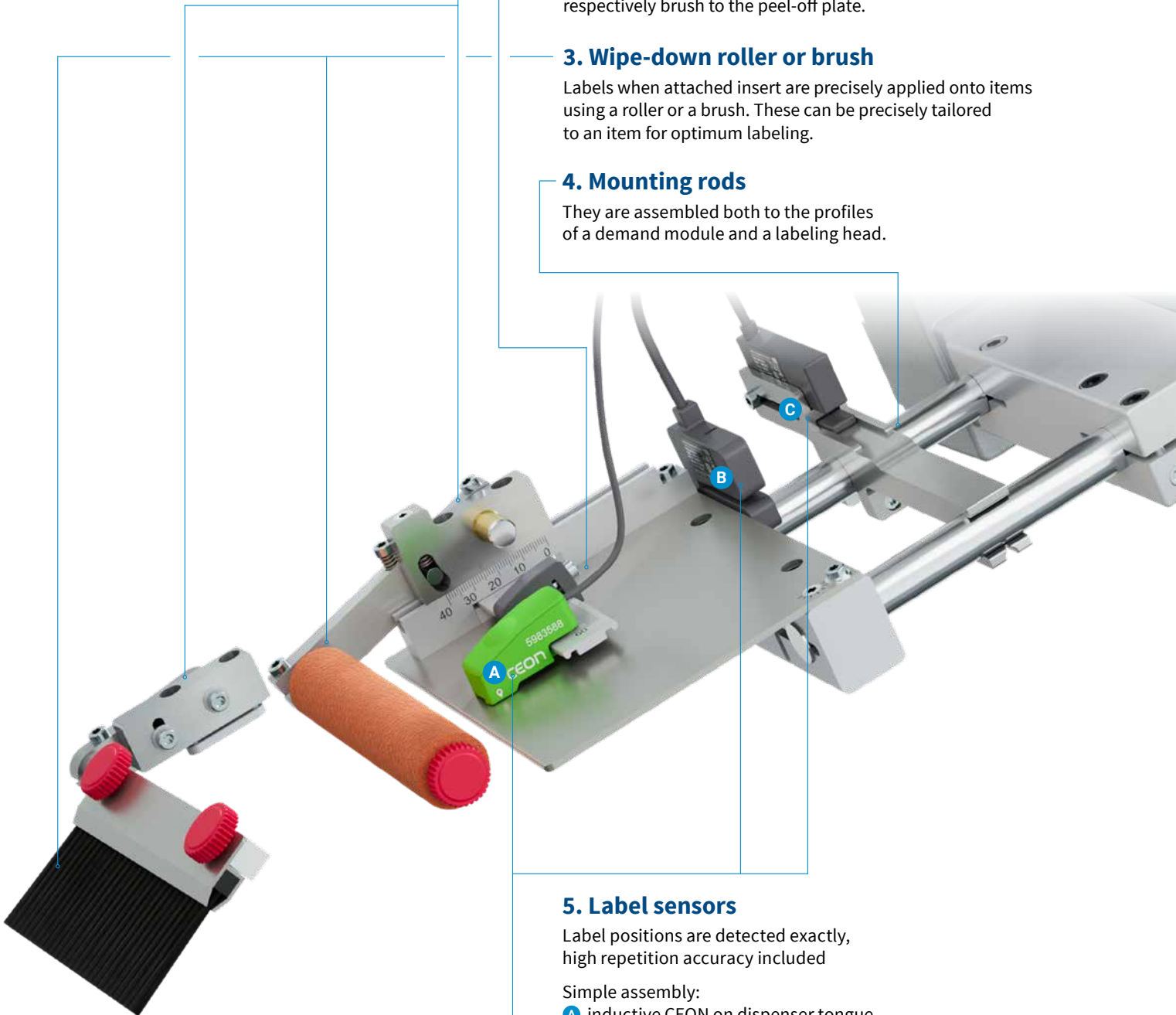

Demand modules



A demand module consists of a dispenser tongue ① and a guide ②.

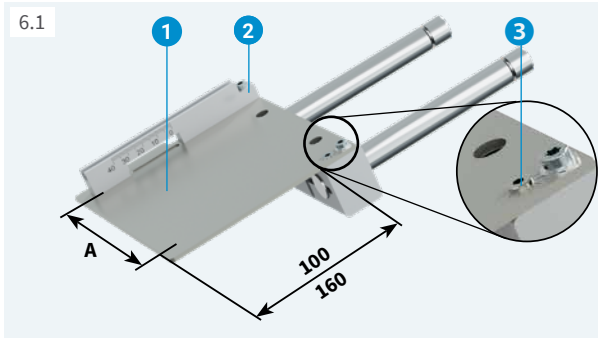

SP demand modules

They are attached to the two mounting rods. The path of a label web can be aligned even during labeling using an extender ③.

Demand module	Direction to which labels are provided		Dimensions A mm
	Types left	Types right	
	SP 100/60L	SP 160/60L	62
	SP 100/120L	SP 160/120L	124
	SP 100/180L	SP 160/180L	186
	SP 100/60R	SP 160/60R	62
	SP 100/120R	SP 160/120R	124
	SP 100/180R	SP 160/180R	186

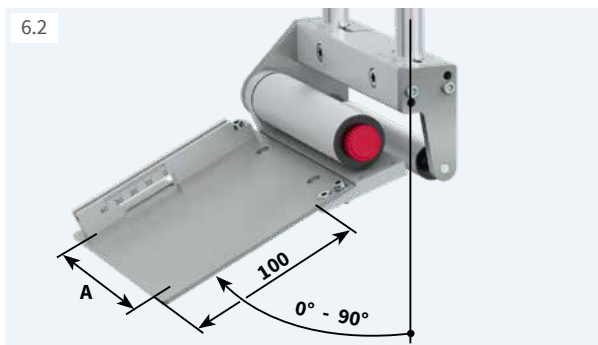

SPE demand modules, adjustable

For better operation or when space is limited, a labeling head may be installed rotated in vertical direction. Applying labels then requires a dispenser tongue continuously adjustable from 0° to 90°.

Demand module	Direction to which labels are provided		Dimensions A mm
	Types left	Types right	
	SPE 100/60L	SPE 100/60R	62
	SPE 100/120L	SPE 100/120R	124
	SPE 100/180L	SPE 100/180R	186

Dispenser tongue 160 upon request

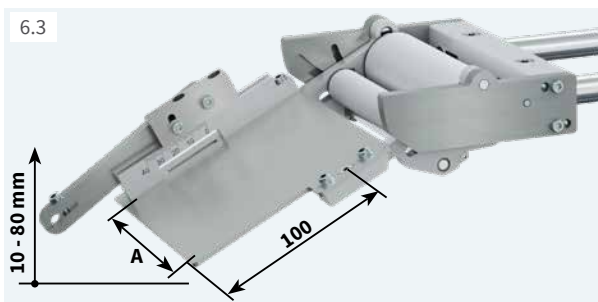

SPFA demand modules, spring-forced, pivotable

When labeling insert onto curved surfaces, a dispenser tongue may adapt to the surfaces and heights of items by spring force. Pivoting heights can be adjusted from 10 mm to 80 mm. Use requires a wipe-down roller.

Demand module	Direction to which labels are provided		Dimensions A mm
	Types left	Types right	
	SPFA 100/60L	SPFA 100/60R	60
	SPFA 100/120L	SPFA 100/120R	120
	SPFA 100/180L	SPFA 100/180R	180

Dispenser tongue 160 upon request

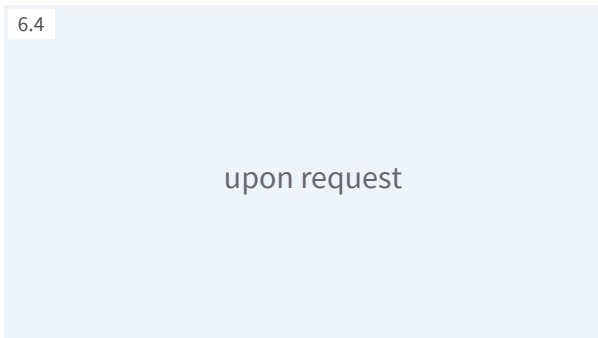

SPZP demand modules, dispenser tongue pneumatically pivotable

The dispenser tongue can be pivoted pneumatically when dealing with sensitive surfaces, when labeling onto cylindrical items or into pockets. Pivoting heights are 10 mm to 20 mm. Use requires a wipe-down roller.

Demand module	Direction to which labels are provided		Dimensions A mm
	Types left	Types right	
	SPZP 100/60L	SPZP 100/60R	60
	SPZP 100/120L	SPZP 100/120R	120
	SPZP 100/180L	SPZP 100/180R	180

Dispenser tongue 160 upon request

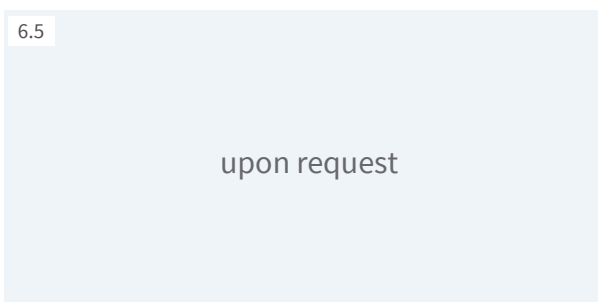

SPAP demand modules, wipe-down roller pneumatically pivotable

A wipe-down roller can be pivoted pneumatically when dealing with sensitive surfaces, when labeling onto cylindrical items or into pockets. Pivoting heights as high as 10 mm

Demand module	Direction to which labels are provided		Dimensions A mm
	Types left	Types right	
	SPAP 100/60L	SPAP 100/60R	60
	SPAP 100/120L	SPAP 100/120R	120
	SPAP 100/180L	SPAP 100/180R	180

Dispenser tongue 160 upon request

6.6 - 6.8

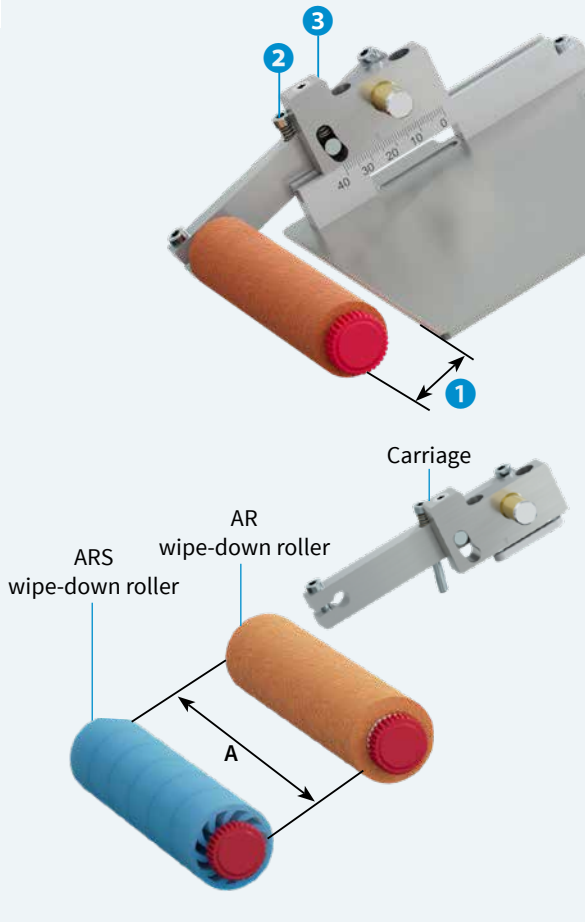

Carriages for assembling a wipe-down roller
They are installed on the guide of a demand module.

- Three-part adjustment of wipe-down roller:
- 1 Distance 5 mm to 40 mm to a peel-off plate
 - 2 Lower end position of roller to an item
 - 3 Wipe-down force onto an item by spring preload

Direction to which labels are provided	Type left	Type right
Carriage	AL	AR

AR wipe-down rollers

Material: open-cell foam for standard applications
The roller is installed on the lever.
It can be replaced without tools when worn.

	Types	Dimensions A mm
Wipe-down roller	AR 60	62
	AR 120	124
	AR 180	186

ARS wipe-down rollers

Material: FDA approved silicone
10 times longer service life compared to open-cell foam
Suitable for food applications and clean rooms
The roller is installed on the lever.
It can be replaced without tools when worn.

	Types	Dimensions A mm
Wipe-down roller	ARS 40	41
	ARS 60	62
	ARS 120	124
	ARS 180	186

6.9, 6.10

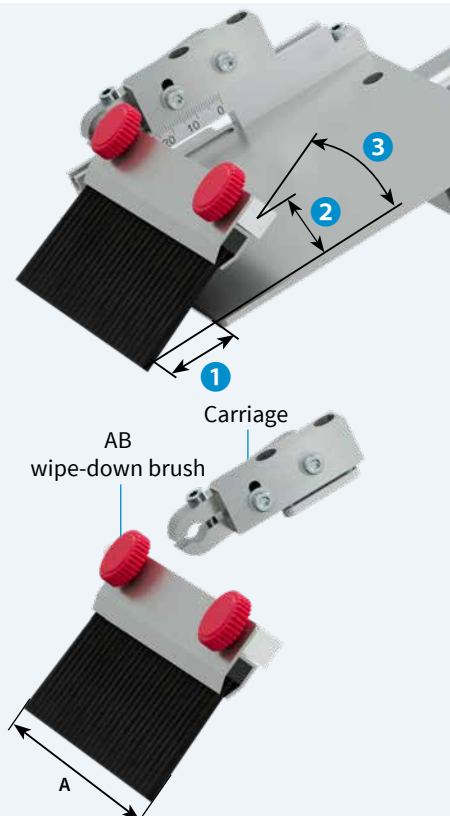

Carriage for assembling a wipe-down brush
It is installed on the guide of a demand module.

- Three-part adjustment of wipe-down brush:
- 1 Distance 1 mm to 35 mm to a peel-off plate
 - 2 Height to a peel-off plate
 - 3 Angle of 15° to 45°

Direction to which labels are provided	Type left and right
Carriage	B

AB wipe-down brushes

Use with standard labels at least 20 mm wide and 20 mm high.
The brush is installed directly on the carriage using a square shaft.
It can be replaced without tools when worn.

	Types	Dimensions A mm
Wipe-down brush	AB 60	62
	AB 120	124
	AB 180	186

Mounting rods

6.11

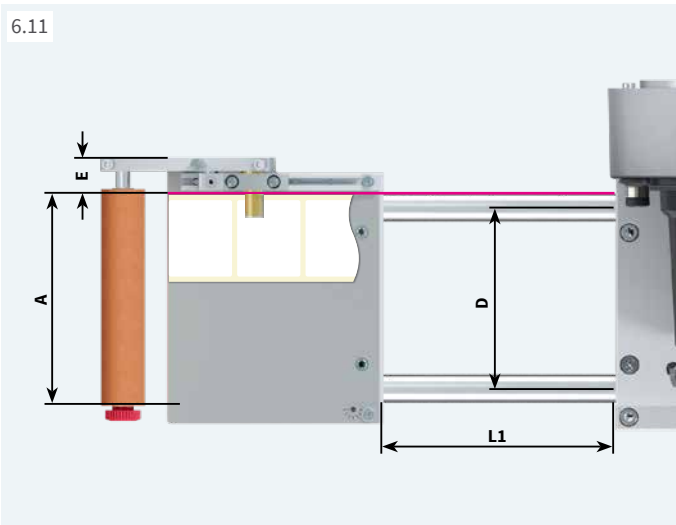

Mounting rods

They connect a labeling head to a demand unit. Two mounting rods are required per unit.

	Types	Dimensions L1 mm
Mounting rod	MS 25	25
	MS 100	100
	MS 200	200
	MS 300	300
	MS 400	400

Further lengths upon request

	Dim. E mm		Dim. A mm	Dim. D mm
SP demand module	20	SPxx 60 demand module	60	104
SPE demand module	24	SPxx 120 demand module	120	104
SPFA demand module	20	SPxx 180 demand module	180	166

Cross-section profiles

6.12

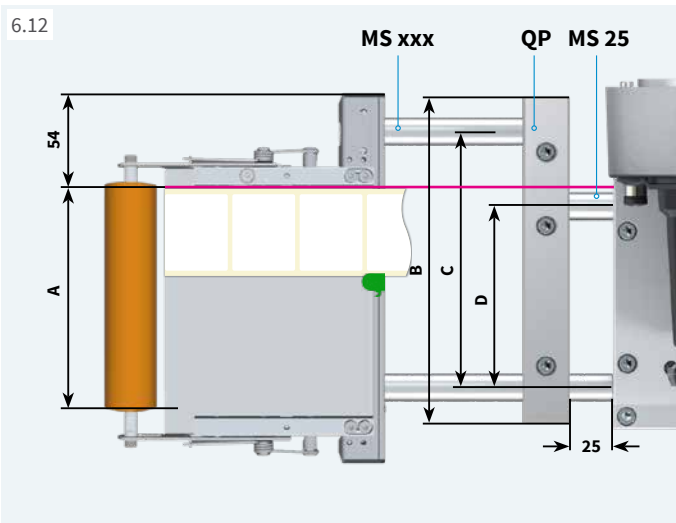

Assembly of IXOR peel-off plates and wipe-down rollers to ROXI Dimension D is adjusted to C using a QP cross-section profile and MS 25 mounting rods.

MS xxx mounting rods must be shortened by 40 mm.

	Types	Dispenser tongue Dimensions A mm	Dim. B mm	Dim. C mm	Dim. D mm
Profile	QP 186	62	186	146	104
	QP 186	124	186	146	104
	QP 248	186	248	208	166
Rod	MS 25	–	–	–	–

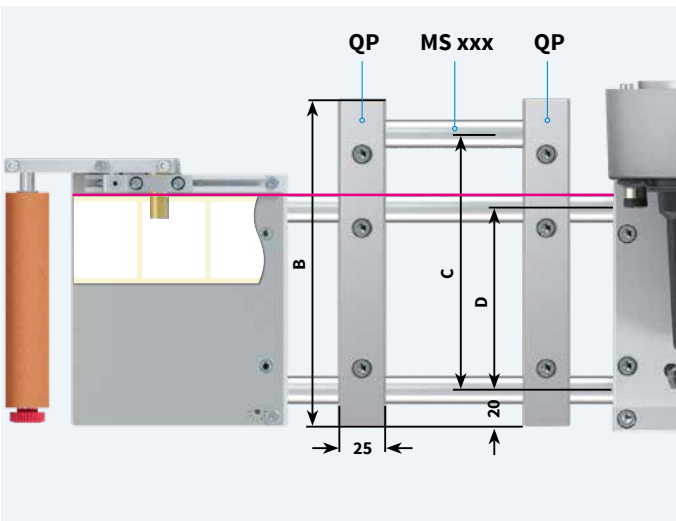

MS xxx as a third mounting rod and further QP cross-section profiles may be added for reinforcing long mounting rods or attaching accessories. Lengths according to application

	Types	Dimensions B mm	Dimensions C mm	Dimensions D mm
Profile	QP 186	186	146	104
	QP 248	248	208	166

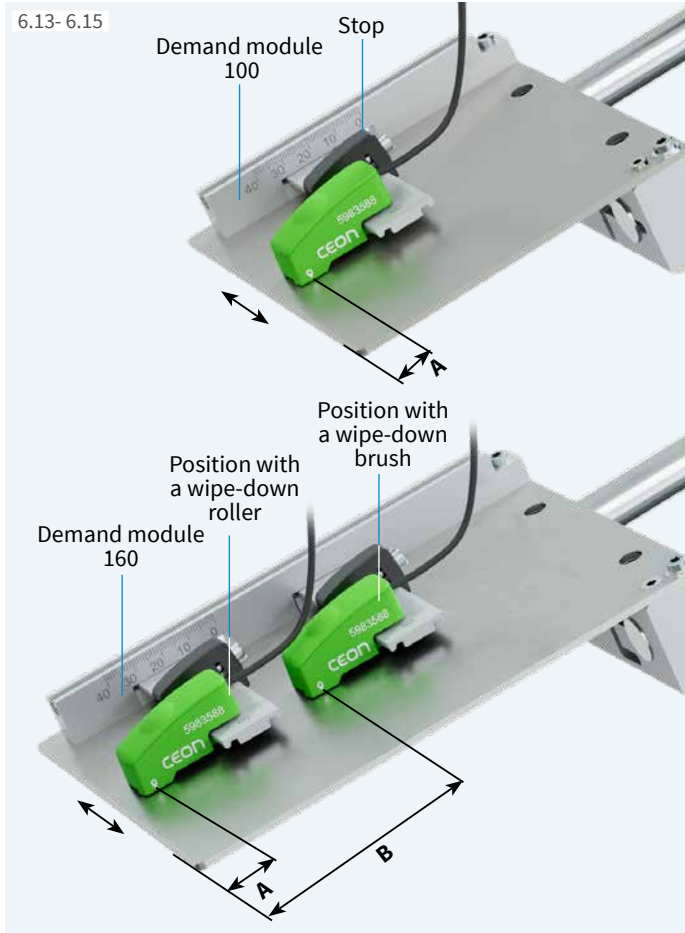

CEON label sensor

It is connected to the labeling head via a smart communication interface. Teaching is performed on the operation panel. Entire calibration takes just two labels.

A ceramic probe inductively detects the difference in height from a liner to the top of a label. The sensor can be aligned along the retainer bar. Distances can be easily set using a scale.

		CEON label sensor
Functional method		inductive, using a ceramic probe
Material Label		paper, synthetics, opaque or transparent
Liner		opaque, transmissive or transparent
Thickness of a label	mm	0.05 - 1.0
Gap between labels	mm	>2
Accuracy of repetition	mm	± 0.05
Connecting cable	length mm	600

Stop

It is adjustable for accurate spotting after sensor disassembly.

Retainer bar

Three lengths are provided. It is assembled in conjunction with a stop onto the dispenser tongue. Distance A is optimized for wipe-down rollers and brushes.

	Types	Sensor distant to locating edge mm	With stop in use mm
Retainer bar	CEON 30	10 - 30	20 - 30
	CEON 60	10 - 60	20 - 60
	CEON 90	10 - 90	20 - 90
Distance to locating edge	Dimension A is alignable from 14 mm to 24 mm A wipe-down roller is recommended with 14 mm, 24 mm prefers a wipe-down brush. Dimension B 74 mm prefers a wipe-down brush.		



GAB 500-1 forked light barrier

Assembled onto a demand module

Sensor distances to the locating edge are 7.5 mm to 17.5 mm

		GAB 500-1 forked light barrier
Functional method		optical, transmitter / receiver
Material Label		paper, synthetics, opaque
Liner		transmissive, transparent
Material gap	mm	3
Gap between labels	mm	>2
Accuracy of repetition	mm	± 0.05
Range of adjustable distance C to locating edge	mm	7.5 - 17.5

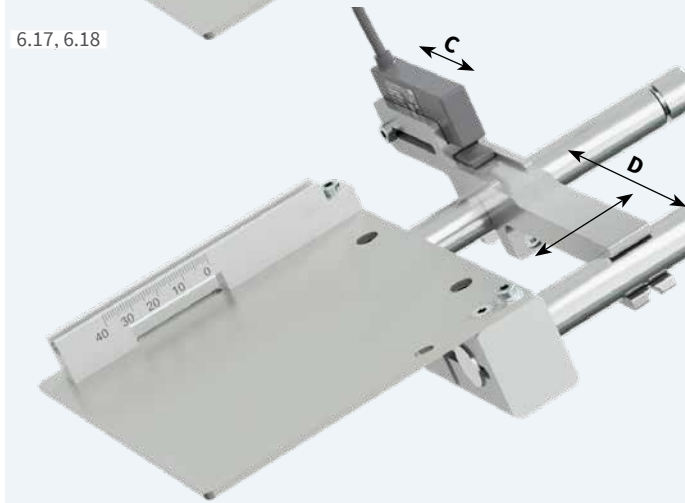

GAB 500-2 forked light barrier

Assembled onto a retainer

Sensor distances to the locating edge are 8.0 mm to 40 mm.

		GAB 500-2 forked light barrier
Functional method		optical, transmitter / receiver
Material Label		paper, synthetics, opaque
Liner		transmissive, transparent
Material gap	mm	5
Gap between labels	mm	>2
Accuracy of repetition	mm	± 0.05
Range of adjustable distance C to locating edge	mm	8.0 - 40

Retainer for assembly at any spot to mounting rods, fixed by screws

	Types	Dimensions D mm
Retainer	GAB 500-2/124	104
	GAB 500-2/186	166

Options

ROXI IXOR+

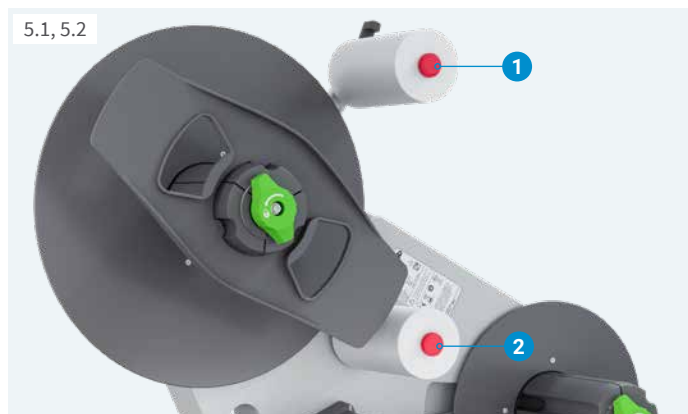

UR D60 deflection rollers

Deflection rollers ① and ② with a diameter of 60 mm help with materials that detach from a liner material when bent at a tight radius.

	Types	Diameters mm	Widths B mm
Deflection roller	UR D60/62	60	62
	UR D60/124	60	124
	UR D60/186	60	186
Guide	FR D60	-	-

② cannot be installed on an IXOR+ base unit

Anti-stick-coated deflection rollers can be provided upon request.

Accessories



Product sensor

Dispensing a label is triggered as soon as an item has been detected. 200 mm maximum detectable track

Product sensor cable

M12-M8, 5 pins, a-coded, 2.5 m included



Rotary encoder

Incremental, resolution 0.1 mm, tracked A and B

Connecting cable M12, 5 pins, a-coded, 2.5 m for automatically synchronizing the speed of labeling
Unlocked by key



Friction wheel

Circumference 200 mm, diameter 63.7 mm



Retainer

It presses a friction wheel by spring force onto a conveyor. Assembly to a conveyor requires a mounting bracket.

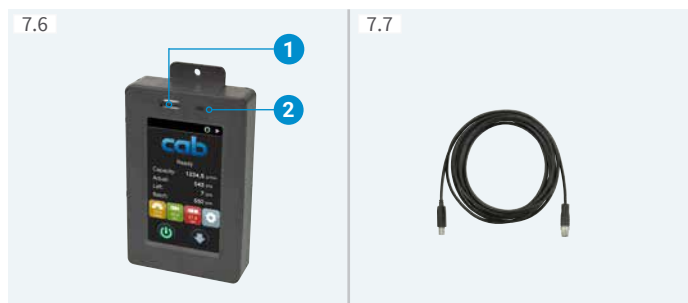

External operation panel

Same functionality as on a labeling head

Users are free to decide whether to operate an external panel or the one integral to a dispenser.

① **USB slot**, transmitting configuration or firmware transfer

② **LED**: Power ON

ROXI: Connecting USB cables 1.8 m, 3 m, 5 m (11 m upon request)

IXOR+: Connecting apply cable 6 m



Warning light

Plugged to a labeling head

Red Collective error, e.g. label web ending, broken liner

Yellow Prior warning to a label web ending

Green Unit ready

Connecting USB cable 1 m

Plugging to IXOR+ in addition requires a connecting apply cable M12, 12 pins, 0.2 m

Cables and plugs

ROXI IXOR+



Cable plug M12, 5 pins, a-coded, male

Circular connector to base unit START, PRINT & APPLY, STOP



Cable jack M12, 5 pins, a-coded, female

Circular connector to base unit SYNC



Distributor / adapter Ethernet for redundant operations

The product sensor and the rotary encoder each are provided once for both labeling heads. Signals are transmitted to both labeling heads via a distributor.

Distributor M12, 5 pins, a-coded:

1 x female → 2 x male for a product sensor

1 x male → 2 x female for a rotary encoder

Ethernet connection requires a **RJ45 adapter**.



I/O interface cable, wire-end-ferruled

M12, 17 pins, 5 m

Extending I/O cable

M12, 17 pins, 2.5 m, 10 m



Extending SYNC cable

for rotary encoder, redundancy / M12, 5 pins, a-coded, 2.5 m, 10 m

for CEON and mechanical unwinder on IXOR+, if assembled separately / M12, 5-polig, a-codiert, 0,5 m

Cables

IXOR+



Connecting APPLY cable for USB host

M12, 12 pins, 0.2 m



Power cable, wire-end-ferruled

2.5 m, 5 m, 10 m



Power cable, plugged type E+F

2.5 m



Ethernet cable

M12, 4 pins, d-coded on RJ45, 2.5 m, 5 m, 10 m

Assembly assistance

ROXI IXOR+

Labeling heads may be installed user-specific into production lines or labeling systems.

Unit retainers with tie rods and column stands with accessories make up a construction kit.

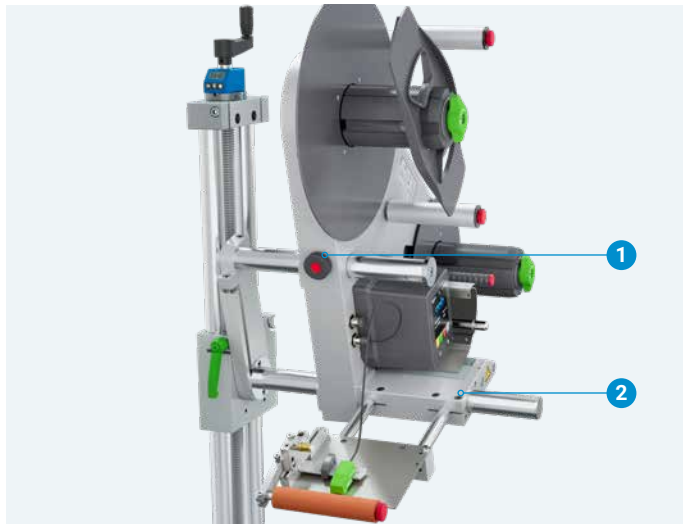

Movable unit retainers

A labeling head is mounted on two columns. On these, dispensing spots can be adjusted transversely to the direction of product transport.

Fixation

ROXI: on chassis using a knurled screw **1**

IXOR+: on mounting strip using a screw **2**

Preferred with vertical installation of a labeling head.

Operating the crank when assembling onto a column frame requires a minimum distance of 40 mm between the tie rod and the chassis.



Unit retainers adjustable by spindle

They enable precise dispensing spots. Adjustments by spindle are possible with labeling heads been installed either vertically or horizontally. The hand crank enables a dispensing spot shifted by 3 mm per rotation.



Column stand providing an adjusting disc

The column stand ensures a labeling head remain stable even when shifted over a long distance. It can be precisely adjusted to a dispensing spot either in vertical and horizontal installation.

The dispensing angle can be set using the adjusting disc.

Unit retainers

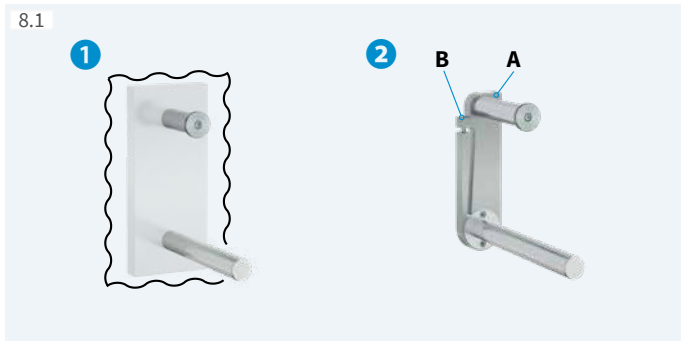

1 Plate / profile assembly

Both rods can be assembled directly onto a plate or a profile.

2 Assembly by tie rod

It allows adjusting the dispensing angle to a product.

The upper rod is clamped to the tie rod and secured by screw A. The lower rod and the collar bearing are screwed to the column stand or a plate.

The tie rod can be swiveled on the collar bearing and locked in place with screw B..

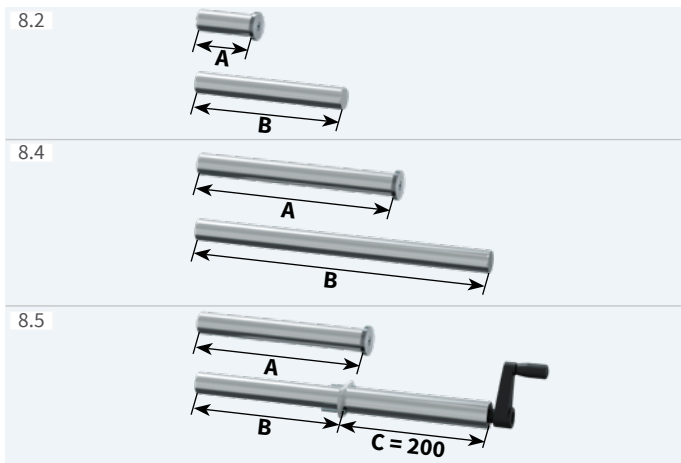

	Types	Adjustable track		Column length	
		Tie rod mm	Plate mm	Dim. A mm	Dim. B mm
Unit retainers fixed	GHF 120	0	20	80	226
	GHF 180	0	20	80	288
Unit retainers movable	GHV 120/100	100	120	180	325
	GHV 180/100	100	120	180	390
	GHV 120/200	200	220	280	425
	GHV 180/200	200	220	280	490
Unit retainers adjustable by spindle	GHS 120/150	150	150	230	225 - 375
	GHS 180/150	150	150	230	286 - 498

Column stands



1 Column stands

Assembly of a labeling head onto a base plate or a conveyor
Position setting using a hand crank. Column diameter 30 mm

	Types	Column length mm	Adjustable track mm
Column stands	SST 400	400	195
	SST 600	600	395
	SST 800	800	595

2 Adjusting disc

It is assembled to the carriage of the column.
Another column stand is attached to it rotatable in vertical direction. Adjustable angles are 0° to 45°

3 Carrier plate with unit retainer GHF

It is screwed onto the front of the column stand guide.
The separate unit retainer can be attached according to the direction to which labels are provided (left or right).

- TP 120 carrier plate**
- TP 180 carrier plate**

Delivery program

ROXI IXOR+

Labeling heads

If order implies protocols and encoders been unlocked and / or options been assembled ex factory, item numbers are added by .250.

ROXI as fast as 30 m/min

Labels provided to the left

Pos.	Item no.	Designation
1.1	6130760.xxx	ROXI 60 L labeling head
1.2	6130120.xxx	ROXI 120 L labeling head
1.3	6130180.xxx	ROXI 180 L labeling head

Labels provided to the right

Pos.	Item no.	Designation
1.1	6130765.xxx	ROXI 60 R labeling head
1.2	6130125.xxx	ROXI 120 R labeling head
1.3	6130185.xxx	ROXI 180 R labeling head

ROXI labeling head type code index		60 L	
Maximum width of a roll	60 mm 120 mm 180 mm	L to the left R to the right	Labels provided

IXOR+ as fast as 50 m/min

Labels provided to the left

Pos.	Item no.	Designation
2.1	6130806.xxx	IXOR+ 50 D310 H 62 L labeling head
	6130808.xxx	IXOR+ 50 D310 H 124 L labeling head
	6130810.xxx	IXOR+ 50 D310 H 186 L labeling head
2.2	6130800.xxx	IXOR+ 50 D310 V 62 L labeling head
	6130802.xxx	IXOR+ 50 D310 V 124 L labeling head
	6130804.xxx	IXOR+ 50 D310 V 186 L labeling head
2.3	6130818.xxx	IXOR+ 50 D410 H 62 L labeling head
	6130820.xxx	IXOR+ 50 D410 H 124 L labeling head
	6130822.xxx	IXOR+ 50 D410 H 186 L labeling head
2.4	6130812.xxx	IXOR+ 50 D410 V 62 L labeling head
	6130814.xxx	IXOR+ 50 D410 V 124 L labeling head
	6130816.xxx	IXOR+ 50 D410 V 186 L labeling head

Labels provided to the right

Pos.	Item no.	Designation
2.1	6130807.xxx	IXOR+ 50 D310 H 62 R labeling head
	6130809.xxx	IXOR+ 50 D310 H 124 R labeling head
	6130811.xxx	IXOR+ 50 D310 H 186 R labeling head
2.2	6130801.xxx	IXOR+ 50 D310 V 62 R labeling head
	6130803.xxx	IXOR+ 50 D310 V 124 R labeling head
	6130805.xxx	IXOR+ 50 D310 V 186 R labeling head
2.3	6130819.xxx	IXOR+ 50 D410 H 62 R labeling head
	6130821.xxx	IXOR+ 50 D410 H 124 R labeling head
	6130823.xxx	IXOR+ 50 D410 H 186 R labeling head
2.4	6130813.xxx	IXOR+ 50 D410 V 62 R labeling head
	6130815.xxx	IXOR+ 50 D410 V 124 R labeling head
	6130817.xxx	IXOR+ 50 D410 V 186 R labeling head

IXOR+ labeling head type code index		50 D410 V 124 L	
Maximum label web speed 50 m/min		L to the left R to the right	Labels provided
Maximum roll diameter	310 mm 410 mm	62 mm 124 mm 186 mm	Maximum width of a roll
		horizontal vertical	Installation

Scope of delivery

ROXI / IXOR+ labeling head
ROXI: Type E+F power cable, 1.8 m
Knowledge Base

Labeling heads and demand units are delivered unassembled in one package.

Provided online



Assembly instructions DE / EN / FR
Configuration manuals DE / EN / FR
Service manuals DE / EN
Spare parts lists DE / EN
Programming manual EN

<https://setup.cab.de/en>



See current data also on the Internet:
www.cab.de/en/labeling-heads

Delivery program

ROXI IXOR+

Labeling heads

If order implies protocols and encoders been unlocked and / or options been assembled ex factory, item numbers are added by .250.

IXOR+ as fast as 75 m/min Labels provided to the left

Pos.	Item no.	Designation
2.5	6130836.xxx	IXOR+ 75 D410 H 62 L labeling head
	6130838.xxx	IXOR+ 75 D410 H 124 L labeling head
	6130840.xxx	IXOR+ 75 D410 H 186 L labeling head
2.6	6130830.xxx	IXOR+ 75 D410 V 62 L labeling head
	6130832.xxx	IXOR+ 75 D410 V 124 L labeling head
	6130834.xxx	IXOR+ 75 D410 V 186 L labeling head

Labels provided to the right

Pos.	Item no.	Designation
2.5	6130837.xxx	IXOR+ 75 D410 H 62 R labeling head
	6130839.xxx	IXOR+ 75 D410 H 124 R labeling head
	6130841.xxx	IXOR+ 75 D410 H 186 R labeling head
2.6	6130831.xxx	IXOR+ 75 D410 V 62 R labeling head
	6130833.xxx	IXOR+ 75 D410 V 124 R labeling head
	6130835.xxx	IXOR+ 75 D410 V 186 R labeling head

IXOR+ as fast as 120 m/min Labels provided to the left

Pos.	Item no.	Designation
2.7	6130856.xxx	IXOR+ 120 D410 H 62 L labeling head
	6130858.xxx	IXOR+ 120 D410 H 124 L labeling head
	6130860.xxx	IXOR+ 120 D410 H 186 L labeling head
2.8	6130850.xxx	IXOR+ 120 D410 V 62 L labeling head
	6130852.xxx	IXOR+ 120 D410 V 124 L labeling head
	6130854.xxx	IXOR+ 120 D410 V 186 L labeling head

Labels provided to the right

Pos.	Item no.	Designation
2.7	6130857.xxx	IXOR+ 120 D410 H 62 R labeling head
	6130859.xxx	IXOR+ 120 D410 H 124 R labeling head
	6130861.xxx	IXOR+ 120 D410 H 186 R labeling head
2.8	6130851.xxx	IXOR+ 120 D410 V 62 R labeling head
	6130853.xxx	IXOR+ 120 D410 V 124 R labeling head
	6130855.xxx	IXOR+ 120 D410 V 186 R labeling head

IXOR+ labeling head type code index	75	D410	V	124	L	
Maximum label web speed	75 m/min					L to the left
	120 m/min					R to the right
Maximum roll diameter	310 mm					62 mm
						124 mm
						186 mm
						horizontal
						vertical
						Installation

Protocols and encoders

If order implies unlocking ex factory, item numbers are added by .250.
In cases of separate unlocking, .001 is added.

Pos.	Item no.	Designation
4.1	5581022.xxx	FQ MQTT
		FM ModBus
		FP Profinet (in preparation)
		FO OPC UA Server
4.2	5581023.xxx	FR MQTT redundancy
4.3	5581020.xxx	ME Masterencoder

Options

If order implies assembly ex factory, item numbers are added by .250.
In cases of separate delivery, .001 is added.

Pos.	Item no.	Designation
5.1	5908002.xxx	UR D60/62 deflection roller
	5907996.xxx	UR D60/124 deflection roller
	5907995.xxx	UR D60/186 deflection roller
5.2	6130629.xxx	FR D60 guide

Scope of delivery

ROXI / IXOR+ labeling head
Knowledge Base

Labeling heads and demand units are delivered unassembled in one package.

Provided online



Assembly instructions DE / EN / FR
Configuration manuals DE / EN / FR
Service manuals DE / EN
Spare parts lists DE / EN
Programming manual EN

<https://setup.cab.de/en>





Delivery program

ROXI IXOR+





If order implies demand units and its components been assembled ex factory, item numbers are added by .250. In cases of separate delivery, .001 is added.





Demand units





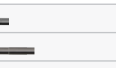
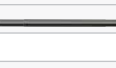

Labels provided to the left

Pos.		Item no.	Designation
6.1		6130656.xxx	SP 100/60L demand module
		6130657.xxx	SP 100/120L demand module
		6130658.xxx	SP 100/180L demand module
		6130650.xxx	SP 160/60L demand module
		6130651.xxx	SP 160/120L demand module
		6130652.xxx	SP 160/180L demand module
6.2		6130662.xxx	SPE 100/60L demand module
		6130663.xxx	SPE 100/120L demand module
		6130664.xxx	SPE 100/180L demand module
6.3		6130468.xxx	SPFA 100/60L demand module
		6130304.xxx	SPFA 100/120L demand module
		6130553.xxx	SPFA 100/180L demand module
6.4	upon request	6130478.xxx	SPZP 100/60L demand module
		6130479.xxx	SPZP 100/120L demand module
		6130555.xxx	SPZP 100/180L demand module
6.5	upon request	6130531.xxx	SPAP 100/60L demand module
		6130532.xxx	SPAP 100/120L demand module
		6130533.xxx	SPAP 100/180L demand module

Labels provided to the right

Pos.		Item no.	Designation
6.1		6130659.xxx	SP 100/60R demand module
		6130660.xxx	SP 100/120R demand module
		6130661.xxx	SP 100/180R demand module
		6130653.xxx	SP 160/60R demand module
		6130654.xxx	SP 160/120R demand module
		6130655.xxx	SP 160/180R demand module
6.2		6130665.xxx	SPE 100/60R demand module
		6130666.xxx	SPE 100/120R demand module
		6130667.xxx	SPE 100/180R demand module
6.3		6130477.xxx	SPFA 100/60R demand module
		6130310.xxx	SPFA 100/120R demand module
		6130554.xxx	SPFA 100/180R demand module
6.4	upon request	6130481.xxx	SPZP 100/60R demand module
		6130482.xxx	SPZP 100/120R demand module
		6130556.xxx	SPZP 100/180R demand module
6.5	upon request	6130536.xxx	SPAP 100/60R demand module
		6130537.xxx	SPAP 100/120R demand module
		6130538.xxx	SPAP 100/180R demand module

Pos.		Item no.	Designation
6.6		6130648.xxx	AL carriage
		6130649.xxx	AR carriage
6.7		6130460.xxx	AR 60 wipe-down roller
		6130461.xxx	AR 120 wipe-down roller
		6130462.xxx	AR 180 wipe-down roller
6.8		6130620.xxx	ARS 40 wipe-down roller
		6130621.xxx	ARS 60 wipe-down roller
		6130622.xxx	ARS 120 wipe-down roller
		6130623.xxx	ARS 180 wipe-down roller
6.9		6130616.xxx	B carriage
6.10		6130463.xxx	AB 60 wipe-down brush
		6130464.xxx	AB 120 wipe-down brush
		6130551.xxx	AB 180 wipe-down brush
6.11		6120069.xxx	MS 25 mounting rod
		5972418.xxx	MS 100 mounting rod
		5972419.xxx	MS 200 mounting rod
		5972420.xxx	MS 300 mounting rod
		6120067.xxx	MS 400 mounting rod
6.12		6130520.xxx	QP 186 cross-section profile
		6130521.xxx	QP 248 cross-section profile

Pos.		Item no.	Designation
6.13		5983588.xxx	CEON label sensor
6.14		6130600.xxx	CEON 30 retainer bar, stop included
		6130601.xxx	CEON 60 retainer bar, stop included
		6130602.xxx	CEON 90 retainer bar, stop included
6.15		6130582.xxx	CEON stop
6.16		6130452.xxx	GAB 500-1 forked light barrier
6.17		5918670.xxx	GAB 500-2 forked light barrier
6.18		6130690.xxx	500-2/124 retainer
		6130704.xxx	500-2/186 retainer



Wear parts

Pos.		Item no.	Designation
6.19		6127895.001	60 wipe-down roller
		6127896.001	120 wipe-down roller
		6127897.001	180 wipe-down roller
6.20		2 x for	ARS 40 wipe-down roller
		3 x for	ARS 60 wipe-down roller
		6 x for	ARS 120 wipe-down roller
		9 x for	ARS 180 wipe-down roller
6.21		6130572.001	60 wipe-down brush
		6130580.001	120 wipe-down brush
		6130573.001	180 wipe-down brush
6.22		5983437.001	CEON probe

Delivery program

ROXI IXOR+



Accessories

Pos.		Item no.	Designation
7.1		5918702.001	Product sensor
7.2		5918671.001	Product sensor cable M12-M8, 4 pins, a-coded, 2.5 m
7.3		5918979	Rotary encoder Connecting cable 2.5 m included
7.4		5918981	Friction wheel
7.5		5918980	Retainer
7.6		6010186	External operation panel
7.7		5907718.001	ROXI: Connecting USB cable 1.8 m
		5907730.001	ROXI: Connecting USB cable 3 m
		5907750.001	ROXI: Connecting USB cable 5 m
		5551007.001	IXOR+: Connecting USB cable 6 m
7.8		6010560	Warning light Connecting USB cable 1 m included





Plugs

Pos.		Item no.	Designation
7.9		5918483.001	Cable plug M12, 5 pins, a-coded, male
7.10		5918480.001	Cable jack M12, 5 pins, a-coded, female
7.11		5918797.001	Distributor for product sensor M12, 5 pins, a-coded 1 x female → 2 x male
7.12		5918485.001	Distributor for rotary encoder M12, 5 pins, a-coded 1 x male → 2 x female
7.13		5918732.001	RJ45 Ethernet adapter

Cables

Pos.		Item no.	Designation
7.14		5918948.001	I/O interface cable, wire-end-ferruled M12, 17 pins, 5 m
7.15		5918421.001	Extending I/O cable M12, 17 pins, 2.5 m
		5918941.001	Extending I/O cable M12, 17 pins, 10 m
7.17		5918757.001	Extending SYNC cable M12, 5 pins, a-coded, 0.5 m
		5918475.001	Extending SYNC cable M12, 5 pins, a-coded, 2.5 m
		5918942.001	Extending SYNC cable M12, 5 pins, a-coded, 10 m

IXOR+

Pos.		Item no.	Designation
7.18		5918936.001	Connecting apply cable for USB host M12, 12 pins, 0.2 m
7.19		5918758.001	Power cable, wire-end-ferruled 2.5 m
		5918947.001	Power cable, wire-end-ferruled 5 m
		5918943.001	Power cable, wire-end-ferruled 10 m
7.20		5918531.001	Power cable, plugged type E+F 2.5 m
7.21		5918665.001	Ethernet cable M12, 4 pins, d-coded on RJ45, 2.5 m
		5918946.001	Ethernet cable M12, 4 pins, d-coded on RJ45, 5 m
		5918945.001	Ethernet cable M12, 4 pins, d-coded on RJ45, 10 m

Delivery program

ROXI IXOR⁺

If order implies components of assembly assistance been assembled ex factory, item numbers are added by .250. In cases of separate delivery, .001 is added.

Assembly assistance

Pos.		Item no.	Designation
8.1		6130411.001	Tie rod
8.2		6130737.001	GHF 120 unit retainer
		6130754.001	GHF 180 unit retainer
8.3		6130741.001	GHV 120/100 unit retainer
		6130756.001	GHV 180/100 unit retainer
8.4		6130744.001	GHV 120/200 unit retainer
		6130758.001	GHV 180/200 unit retainer
8.5		6130747.001	GHS 120/150 unit retainer
		6130762.001	GHS 180/150 unit retainer
8.6		5983420.xxx	SST 400 column stand
		5983421.xxx	SST 600 column stand
		5983422.xxx	SST 800 column stand
8.7		5972532.001	Adjusting disc
8.8		6131005.001	TP 120 carrier plate
		6131006.001	TP 180 carrier plate
8.9		5919809.xxx	EPOS electronic position indicator
8.10		6131010.xxx	GHS adapter kit for unit retainers
8.11		6131015.xxx	SST adapter kit for column stands

Floor stands

Pos.		Item no.	Designation
8.12		5983425	1632 floor stand SST 600 column stand included
8.13		5983426	1231 floor stand

Delivery program

IXOR+

Labeling head components

If order implies components of labeling heads been assembled ex factory, item numbers are added by .250. In cases of separate delivery, .001 is added.

IXOR+ 50 base units

Labels provided to the left













Pos.		Item no.	Designation
3.1		6130774.xxx	IXOR+ 60 L base unit
3.2		6130776.xxx	IXOR+ 120 L base unit
3.3		6130778.xxx	IXOR+ 180 L base unit

Labels provided to the right













Pos.		Item no.	Designation
3.1		6130775.xxx	IXOR+ 60 R base unit
3.2		6130777.xxx	IXOR+ 120 R base unit
3.3		6130779.xxx	IXOR+ 180 R base unit

Mechanical winders

Labels provided to the left

Pos.	Orientation of assembly V	Orientation of assembly H	Item no.	Designation
3.4			5983326.xxx	D310 H 62 L unwinder
			5983300.xxx	D310 H 124 L unwinder
			5983302.xxx	D310 H 186 L unwinder
			6122000.xxx	D310 V 62 L unwinder
			5983312.xxx	D310 V 124 L unwinder
			5983314.xxx	D310 V 186 L unwinder
3.5			5983328.xxx	D410 H 62 L unwinder
			5983306.xxx	D410 H 124 L unwinder
			5983308.xxx	D410 H 186 L unwinder
			6122002.xxx	D410 V 62 L unwinder
			5983318.xxx	D410 V 124 L unwinder
			5983320.xxx	D410 V 186 L unwinder
3.6			6122030.xxx	D210/62 L rewriter
			6122034.xxx	D210/124 L rewriter
			6122038.xxx	D210/186 L rewriter
3.7			6122032.xxx	D290/62 L rewriter
			6122036.xxx	D290/124 L rewriter
			6122040.xxx	D290/186 L rewriter

Labels provided to the right

Pos.	Orientation of assembly V	Orientation of assembly H	Item no.	Designation
3.4			5983327.xxx	D310 H 62 R unwinder
			5983301.xxx	D310 H 124 R unwinder
			5983303.xxx	D310 H 186 R unwinder
			6122001.xxx	D310 V 62 R unwinder
			5983313.xxx	D310 V 124 R unwinder
			5983315.xxx	D310 V 186 R unwinder
3.5			5983329.xxx	D410 H 62 R unwinder
			5983307.xxx	D410 H 124 R unwinder
			5983309.xxx	D410 H 186 R unwinder
			6122003.xxx	D410 V 62 R unwinder
			5983319.xxx	D410 V 124 R unwinder
			5983321.xxx	D410 V 186 R unwinder
3.6			6122031.xxx	D210/62 R rewriter
			6122035.xxx	D210/124 R rewriter
			6122039.xxx	D210/186 R rewriter
3.7			6122033.xxx	D290/62 R rewriter
			6122037.xxx	D290/124 R rewriter
			6122041.xxx	D290/186 R rewriter

IXOR+ 75/120 base units

Labels provided to the left







Pos.		Item no.	Designation
3.8		6130974.xxx	IXOR+ 60 L M base unit
3.9		6130976.xxx	IXOR+ 120 L M base unit
3.10		6130978.xxx	IXOR+ 180 L M base unit

Labels provided to the right







Pos.		Item no.	Designation
3.8		6130975.xxx	IXOR+ 60 R M base unit
3.9		6130977.xxx	IXOR+ 120 R M base unit
3.10		6130979.xxx	IXOR+ 180 R M base unit

Motoric winders

Labels provided to the left

Pos.	Orientation of assembly V	Orientation of assembly H	Item no.	Designation
3.11			5983596.xxx	D410 H 62 L M unwinder
			5983501.xxx	D410 H 124 L M unwinder
			5983502.xxx	D410 H 186 L M unwinder
			5983592.xxx	D410 V 62 L M unwinder
			5983505.xxx	D410 V 124 L M unwinder
			5983506.xxx	D410 V 186 L M unwinder
3.12			5983594.xxx	D310/62 L M rewriter
			5983531.xxx	D310/124 L M rewriter
			5983532.xxx	D310/186 L M rewriter

Labels provided to the right

Pos.	Orientation of assembly V	Orientation of assembly H	Item no.	Designation
3.11			5983597.xxx	D410 H 62 R M unwinder
			5983540.xxx	D410 H 124 R M unwinder
			5983541.xxx	D410 H 186 R M unwinder
			5983593.xxx	D410 V 62 R M unwinder
			5983544.xxx	D410 V 124 R M unwinder
			5983545.xxx	D410 V 186 R M unwinder
3.12			5983595.xxx	D310/62 R M rewriter
			5983570.xxx	D310/124 R M rewriter
			5983571.xxx	D310/186 R M rewriter

Accessories

Pos.		Item no.	Designation
3.13		5983324.xxx	Counterholder 310 mm
		5983325.xxx	Counterholder 410 mm



Type code	D	410	H	124	L	M
Maximum roll diameters		410 mm				
Installation vertical V						
horizontal H						
						Motoric
						L to the left
						R to the right
						62 mm Maximum
						roll diameter
						124 mm
						186 mm

Delivery program



IXOR+

If order implies components of labeling heads been assembled ex factory, item numbers are added by .250. In cases of separate delivery, .001 is added.

Accessorial components for labeling heads on mounting strips or customer-specific plates

Pos.	Item no.	Designation
3.14	 6120016.xxx	Compact mounting strip
3.15		6127290.xxx D30 AL 62 deflection roller
		6127291.xxx D30 AL 124 deflection roller
		6127292.xxx D30 AL 186 deflection roller
		6127295.xxx D38 AL 62 deflection roller
		6127296.xxx D38 AL 124 deflection roller
		6127297.xxx D38 AL 186 deflection roller
		6127311.xxx D60 AL 62 deflection roller
		6127312.xxx D60 AL 124 deflection roller
6127313.xxx D60 AL 186 deflection roller		

Accessories for assembling onto customer-specific plates

Pos.	Item no.	Designation
3.16	 6127288.001	Spacer bolt for deflection roller
3.17	 6110902.001	Attachment unit for mechanical unwinder
3.18	 6120017.001	Spacer for motoric unwinder, rewinder

For mechanical unwinders, CEON

Pos.	Item no.	Designation
3.16	 5918757.001	Extending SYNC cable M12, 5 pins, a-coded, 0.5 m

For motoric unwinders and rewinders

Pos.	Item no.	Designation
3.17		5918944.001 Connecting PowerBus cable M12, 4 pins, 0.3 m
		5918879.001 Connecting PowerBus cable M12, 4 pins, 0.8 m
		5918426.001 Connecting PowerBus cable M12, 4 pins, 2.5 m

Final assembly, setup and system testing

Pos.	Item no.	Designation
3.18	6129050.250	IXOR+ 50 final assembly and setup
	6129075.250	IXOR+ 75 final assembly and setup
	6129120.250	IXOR+ 120 final assembly and setup
	6129100.250	System testing with customer labels

Packaging

Pos.	Item no.	Designation
3.19	6123310.001	IXOR+ 50 D310 packaging
	6123410.001	IXOR+ 50 D410 packaging
	6123510.001	IXOR+ 75/120 packaging

Overview of cab products

Label printers
MACH1, MACH2



Label printers
EOS 2



Label printers
EOS 5



Label printers
MACH 4S



Label printers
SQUIX 2



Label printers
SQUIX 4



Label printers
SQUIX 6.3



Label printers
SQUIX 8.3



Label printers
XD Q double-sided



Label printers
XC Q two-colored



Print and apply systems
HERMES Q



Print and apply systems
Hermes C two-colored

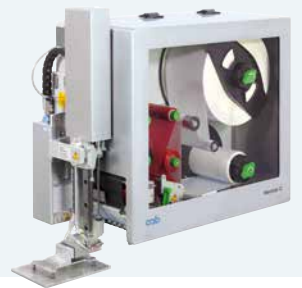

Tube labeling systems
AXON 1



Print modules
PX Q



Labels and ribbons



Label software
cablabel S3



Labeling heads
HS, VS



Labeling heads
IXOR



Marking lasers
XENO 4



Laser marking systems



Germany
cab Produkttechnik GmbH & Co KG
Karlsruhe
Phone +49 721 6626 0
www.cab.de

France
cab Technologies S.à.r.l.
Niedermodern
Phone +33 388 722501
www.cab.de/fr

USA
cab Technology, Inc.
Chelmsford, MA
Phone +1 978 250 8321
www.cab.de/us

Mexico
cab Technology, Inc.
Juárez
Phone +52 656 682 4301
www.cab.de/es

Taiwan
cab Technology Co., Ltd.
Taipei
Phone +886 (02) 8227 3966
www.cab.de/tw

China
cab (Shanghai) Trading Co., Ltd.
Shanghai
Phone +86 (021) 6236 3161
www.cab.de/cn

Singapore
cab Singapore Pte. Ltd.
Singapore
Phone +65 6931 9099
www.cab.de/en

South Africa
cab Technology (Pty) Ltd.
Randburg
Phone +27 11 886 3580
www.cab.de/za

cab // 820 distribution and service partners in more than **80** countries

